

STANDARD SPECIFICATIONS

WORK INCLUDED
The doors will be Series 430 as manufactured by Overhead Door Corporation.

RELATED WORK
Opening preparation, miscellaneous or structural metal work, access panels, finish or field painting, field electrical wiring, wire, conduit, fuses and disconnect switches are in the Scope of Work of other divisions or trades.

SECTIONS
Sections will be nominal 24 ga. roll-formed galvanized and will have a nominal thickness of 2". Doors will have rabbeted meeting rails to form weathertight joints and provide full-width interlocking structural rigidity. Center and end stiles will be 16 ga. steel, formed and fastened as integral structures with the rolled sections. End stiles will be channel-shaped to 2" deep. Deflection of door in the horizontal position will not exceed 1/120 of the door width.

HARDWARE
Hinges and fixtures will be galvanized steel. Full-floating ball-bearing rollers will have hardened steel races. Roller sizes will be adequate for design requirements and limitations.

WEATHERSTRIP
Bottom weatherstrip will be flexible PVC and held in place by a retainer which also provides additional reinforcement.

FINISH
Paint will be baked-on polyester.

INSTALLATION
Install the doors in accordance with Overhead Door Corporation instructions and standards, using an authorized Overhead Door Corporation distributor.

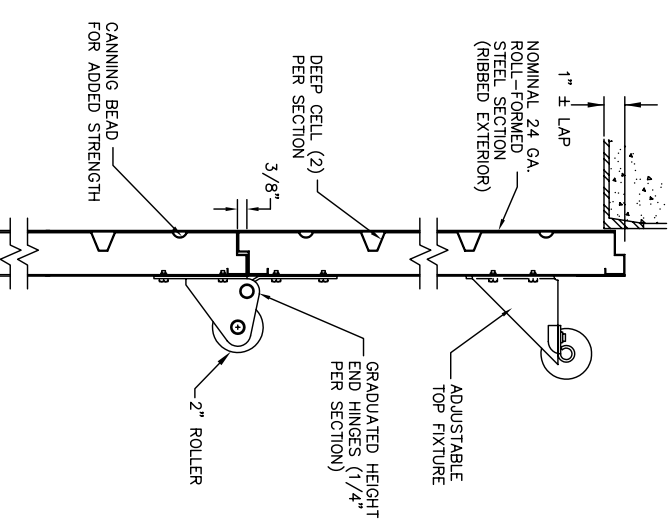
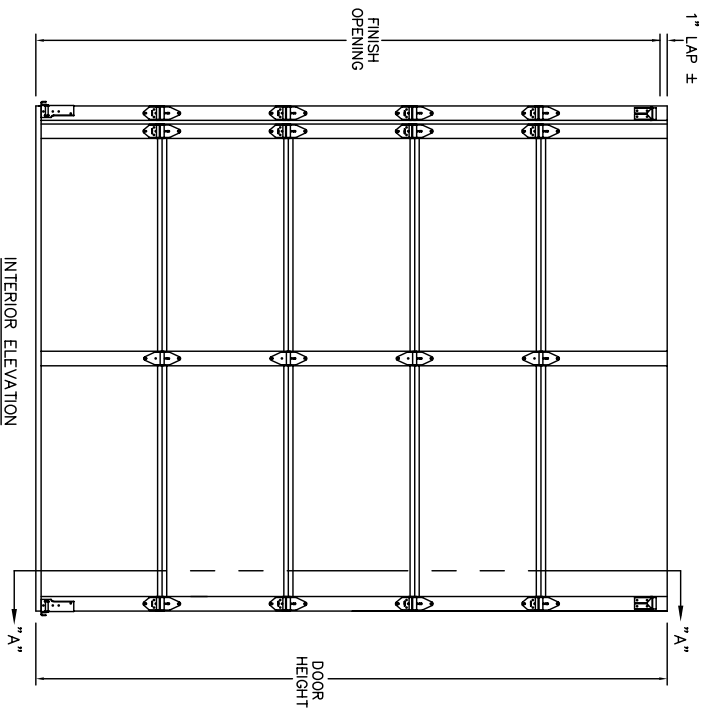

EXHAUST PORT PREP

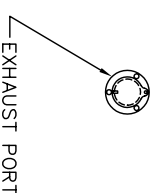

END STILE TYPE:

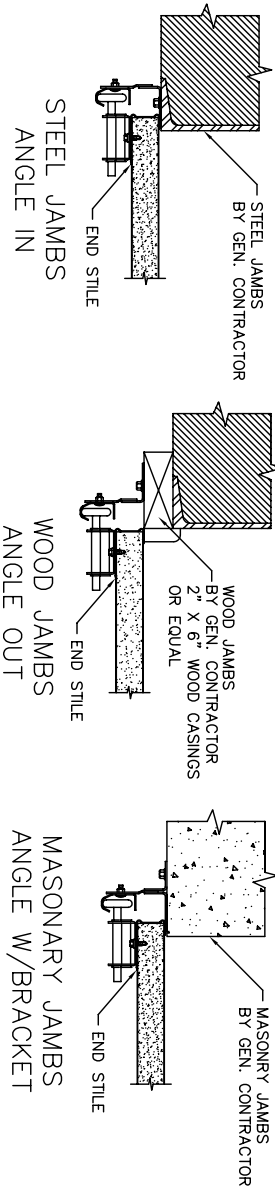

TRACK STYLE:

WINDOW SELECTION

NONE

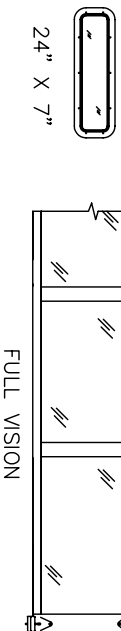

LOCATION AND NUMBER :

DOOR SEALS:

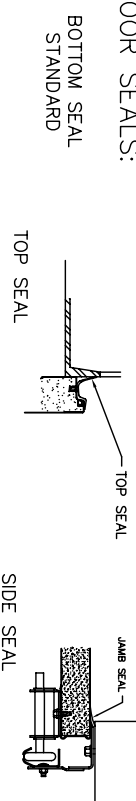

SPRINGS:

SHAFT TYPE:

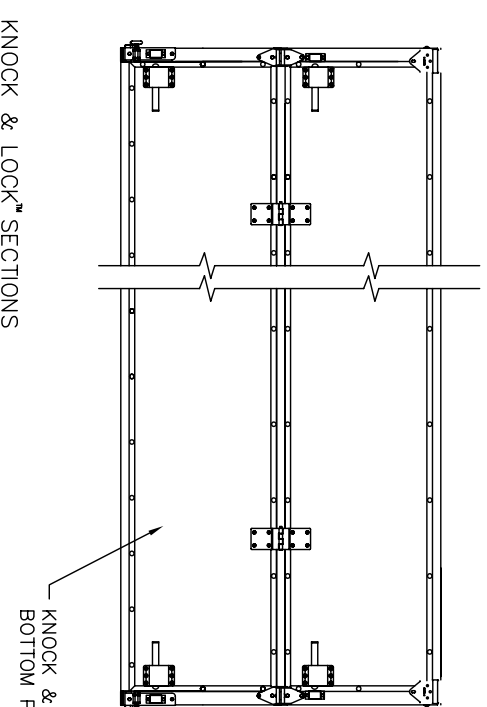

ENGINEERING APPROVAL REQUIRED

KNOCK & LOCKSM SECTIONS
Bottom two sections automatically reset eliminating downtime. Rugged Valtra brand interior skin is highly abrasion resistant and virtually puncture-proof. Two-pound density two-inch thick foam core absorbs and disperses impact energy.

OVERHEAD DOOR MARK	QTY	OPENING SIZE		DOOR SIZE		LIFT TYPE	SECTIONS HIGH	EXTERIOR COLOR
		WIDTH	HEIGHT	WIDTH	HEIGHT			

ADDED OPTIONS : (PER DOOR)

ADDED OPTIONS : (PER DOOR)

PROJECT	430 SERIES, STEELDOORS
ARCHITECT	
CONTRACTOR	
DISTRIBUTOR	
PLANT	
DWG. NO.	DATE:
SHEET	BY:

