

# RMZ Hoist

## MEDIUM-DUTY HOIST



The new Z Series RMZ Hoist is designed for high or full-lift sectional and rolling doors that have a limited-duty cycle requirement. Advanced features and robust mechanical design combine to provide a medium-duty operator that is the new standard in the industry.

### UL 325 Listed

- Allows for monitored entrapment protection and momentary operation when used with select photocells and/or edge-sensing devices.

### RMZ Hoist Advantages

- Rated for 15 cycles per hour operation, maximizing the performance of a medium-duty operator.
- Modular design with optional expansion boards for advanced timer to close and auxiliary output functionality.
- Included internal CodeDodger® receiver learns up to 250 transmitters with randomly assigned identity numbers. Learn and delete individual transmitters directly from LCD display.
- Ball bearing motor with built-in thermal protection and ball bearings isolates motor for quiet operation, provides overload protection and extended motor life due to use of bearings over bushings.
- Open/close/stop and setup keys included on control board. Keeps all controls near the LCD display convenient for set up.
- Electric box isolation from the frame reduces vibration.
- Available as chain couple operator for rolling doors, or direct couple operator for sectional doors.
- Available to chain couple, front of hood mount on coil-away doors.

### Standard Features

- LimitLock® electro-mechanical limits.
- Max run timer automatically adjusts to up and down run time.
- SuperBelt® self-tensioning primary drive reduction
- Delay on reverse.
- 16-character LCD display.
- UL 325 Listed.
- 3-button control station.
- 2-year/20,000-cycle warranty.
- Programmable mid-stop.
- Right or left hand emergency hoist models available for manual operation.
- Built-in cycle count and trouble-shooting assistance via LCD display.



INDUSTRY LEADING  
COMMERCIAL & INDUSTRIAL SOLUTIONS

# RMZ Hoist MEDIUM-DUTY HOIST OPERATOR

## MAX DOOR SIZE (SQ\*FT) - SECTIONAL

Door Series		Commercial Steel Insulated & Non-Insulated								Thermacoré				Aluminum	
		416	416 Ins.	420	420 Ins.	424	424 Ins.	430	430 Ins.	598	591	592	596	511	521
		Flush				Ribbed				Insulated					
Model	Max Door Wt. (lbs.)	16GA.	16GA. Ins.	20GA. Steel	20GA. Ins.	24GA.	24GA. Ins.	Nominal 24GA.	Nominal 24GA. Ins.	PU-FIP	PU-FIP 1.38"	PU-FIP 2"	PU-FIP 2" 20GA. Ext.	1/8" Glass 1.38"	1/4" or 1/2" Glass 1.38"
1/2 HP	620	170	120	230	160	270	200	300	256	256	256	240	160	210	144

## MAX DOOR SIZE (SQ\*FT) - ROLLING

Door Series		Steel Non-Insulated						Steel Insulated			Counter Doors		Grilles	
		16GA.	18GA.	20GA.	22GA.	24GA.	26GA.	18GA.	20GA.	22GA.	Aluminum	STL/SST	Aluminum	STL/SST
Model	Max Door Wt. (lbs.)	68	77	93	105	154	144	53	58	63	Not for counter door use		142	116
1/2 HP	580													

Notes: 1. Max door weight and not the square footage, is the critical factor in selecting the proper operator.  
 2. Max door height 16'  
 3. For "Commercial Steel Insulated" category, various "backer" options are available. The chart above is based in all cases on the thickest backer available.

### Construction

- Motor**  
1/2 HP, 120 VAC capacitor start/run motor. Motor replaceable without changing limits. Thermally protected.
- Brake**  
24 VDC disc brake.
- Drive**  
Primary — SuperBelt® auto tensioning poly-V J belt. Secondary — chain and sprocket reduction.
- Friction Clutch**  
Adjustable clutch to help protect against door and operator damage.
- Emergency Hoist Manual Operation**  
Pull cord release with manual chain hoist.
- Pre-wired to accept:**
  - Monitored entrapment devices
  - Single or 3-button control stations.
  - External interlock switches.

### Accessories and Options

- Timer Close Module**  
Timer close set via the LCD display from 2 seconds up to 5 minutes. Includes pre-close warning contacts, timer hold input, auxiliary open input, normally closed safety input, and T3 monitored edge input. (P/N: OPABTCX.S)
- Auxiliary Output Module**  
Provides relay contacts at the open, close, and mid-stop limits. Contacts for 5-minute lamp, and "ADA" contacts set via LCD display to warn during opening, closing or both. (P/N: OPABIOX.S)
- Edge Sensing Module**  
Input allows connection of a T3 monitored safety edge. When advanced timer close features are required, use the Timer Close Module. (P/N: OPABESX.S)
- UL 325 Approved Reversing Devices**  
The installation of a monitored external entrapment device is required for momentary contact close operation on all commercial door operators. Only the following devices, when purchased through Overhead Door Corporation, are UL approved for use to meet this requirement:

- Safe-T-Beam® Photocell kit with adjustable bracket P/N: 38176R.S 1
- Impact-protected Commercial Photocell Kit P/N: OPAKPE2.S
- NEMA 4X Photocells P/N: OPAKRPEN4GX.S
- Retro Reflective NEMA 4X Photocells P/N: OPAKRPEN4X.S
- Monitored Light Curtains - 3' P/N: OPAKMLC3.S 6'  
P/N: OPAKMLC6.S  
Light curtain mounting brackets (6 total) P/N: 112809.0001.S
- MillerEdge ME/MT/CPT (DC or T3) 2-wire edge sensor. Must be used with TCM (OPABTCX.S), ESM (OPABESX.S), or Interface Module (OPAKMEIX.S).

1 — Default device when operator is ordered.

### AMPERAGE RATING 1PH 60Hz

HP	120V
1/2	6.5

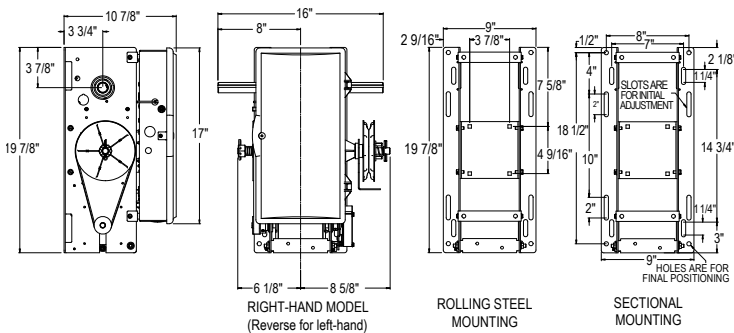

INDUSTRY LEADING  
COMMERCIAL & INDUSTRIAL SOLUTIONS

2501 S. State Hwy. 121 Bus., Suite 200, Lewisville, TX 75067

1-800-929-DOOR • sales@overheaddoor.com

www.OverheadDoor.com

